

**CAUTION:**  
DO NOT USE CONDENSER WINTERGUARD KIT WHEN COMPRESSOR IS ENGAGED IN DEFROST MODE.  
IF OEM COMPRESSOR IS USED DURING DEFROST MODE - IT MUST BE LOCKED OUT BELOW AMBIENT TO PREVENT BEING DAMAGED BY LIQUID SLUGGING.  
INLINE DIODES SHOULD BE RATED FOR AT LEAST 6 AMP 200 VOLT

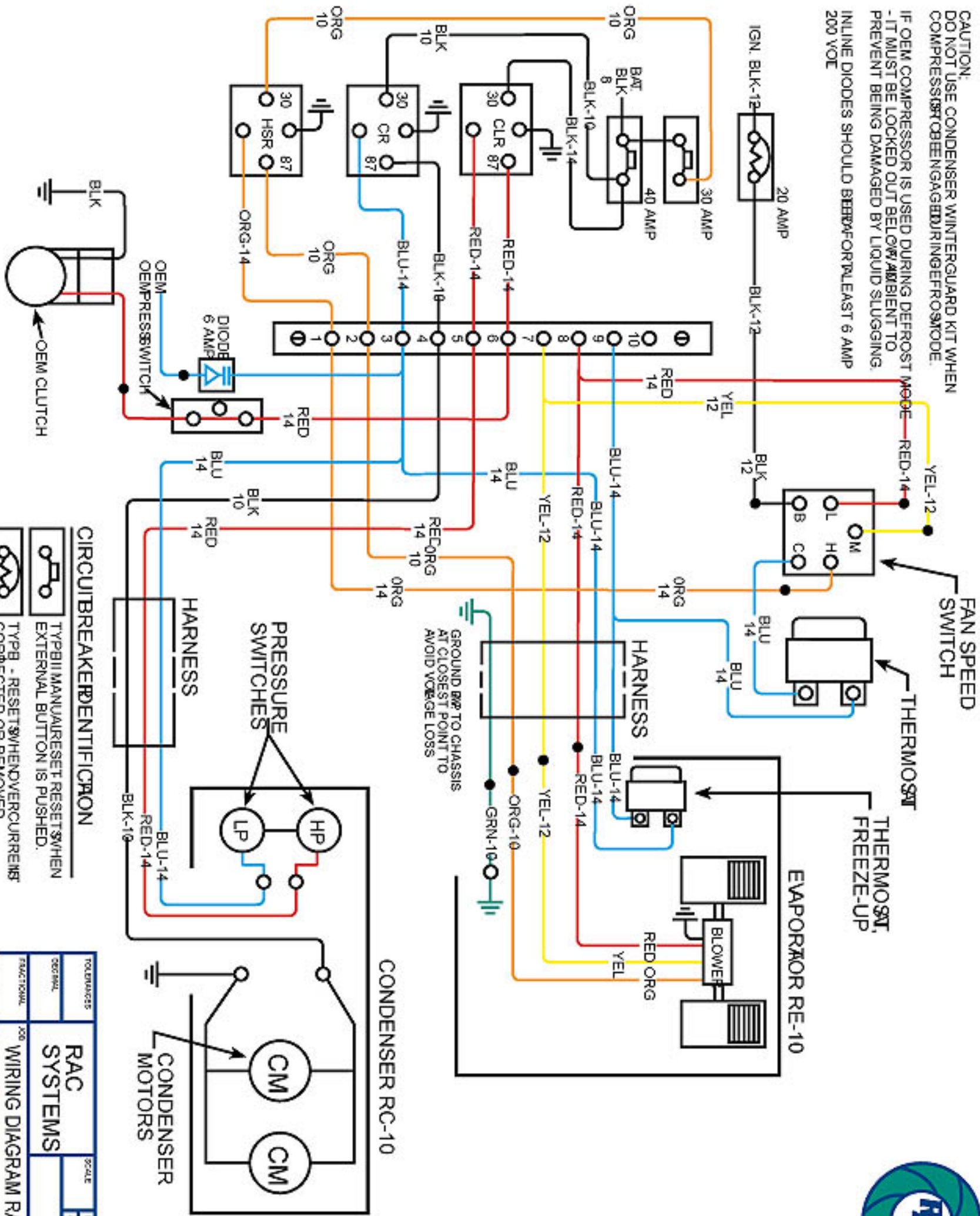

**CIRCUITBREAKER IDENTIFICATION**

- TYPE B II MANUAL RESET WHEN EXTERNAL BUTTON IS PUSHED.
- TYPE B - RESET WHEN OVERCURRENT IS CORRECTED OR REMOVED.

|                                       |          |                 |
|---------------------------------------|----------|-----------------|
| TOLERANCES                            | SCALE    | DRAWN BY        |
| DECIMAL                               |          | APPROVED BY     |
| FRAC T/16                             |          |                 |
| <b>RAC SYSTEMS</b>                    |          |                 |
| <b>WIRING DIAGRAM RAC-1015 TIE-IN</b> |          |                 |
| DATE                                  | DRAWN BY |                 |
|                                       |          | <b>RAC-1015</b> |

